



Technical Data Sheet

Luminosity Full Color LED

61-136/REGHB7C-B07/ET

Features

- Super-luminosity chip LED.
- White SMT package.
- Built in Red, Green, and Blue chips.
- Lead frame package with individual 6 pins.
- Wide viewing angle.
- Soldering methods: IR reflow soldering.
- Pb-free.
- The product itself will remain within RoHS compliant version.
- ESD protection.



Descriptions

- Due to the package design, 61-136 has wide viewing angle , low power consumption and adjusting each color is possible thanks to serial connection by 6 terminal connection (Individual driving by each terminal) in case of using several number of LED. And makes it ideal for light pipe application.

Applications

- Amusement equipment.
- Information boards.
- Flashlight for digital camera of cellular phone.

Device Selection Guide

Chip		Emitted Color	Resin Color
Type	Material		
RE	AlGaInP	Brilliant Red	Water Clear
GH	InGaN	Brilliant Green	
B7	InGaN	Blue	

Technical Data Sheet

Luminosity Full Color LED

61-136/REGHB7C-B07/ET

Package Outline Dimensions

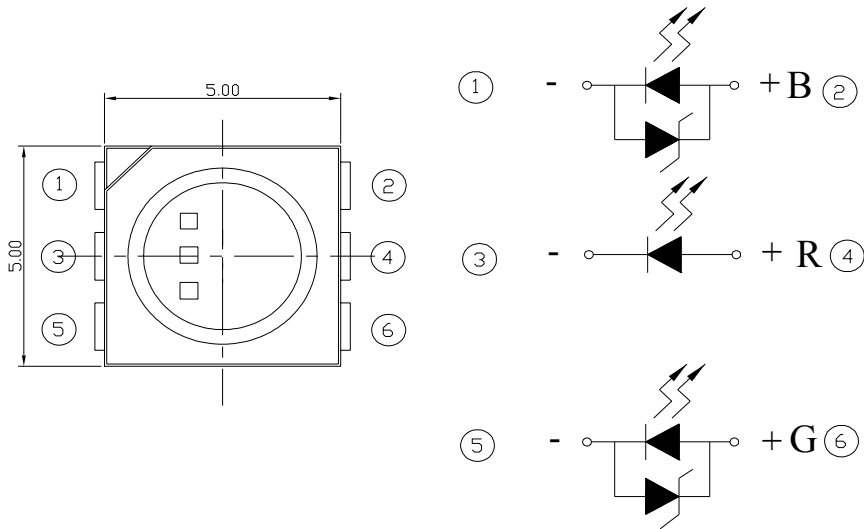

Polarity

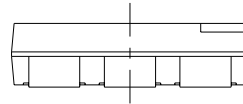
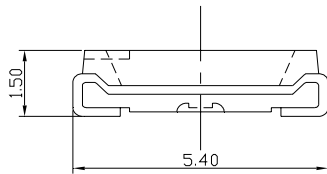

Recommend soldering pad design

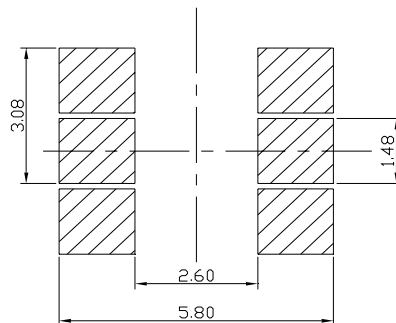
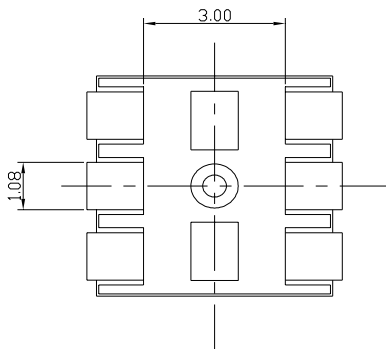

Note: The tolerances unless mentioned: $\pm 0.1\text{mm}$, Unit = mm

**Technical Data Sheet****Luminosity Full Color LED****61-136/REGHB7C-B07/ET****Absolute Maximum Ratings (Ta=25)**

Parameter	Symbol	Rating		Unit
Reverse Voltage	V _R	5		V
Forward Current	I _F	RE	50	mA
		GH	30	
		B7	30	
Peak Forward Current (Duty 1/10 @ 1KHZ)	I _{FP}	RE	100	mA
		GH	100	
		B7	100	
Power Dissipation	Pd	RE	120	mW
		GH	110	
		B7	110	
Electrostatic Discharge(HBM)	ESD	2000		V
Operating Temperature	Topr	-40 ~ +85		
Storage Temperature	Tstg	-40~ +90		
Soldering Temperature	Tsol	Reflow Soldering : 260 for 10 sec. Hand Soldering : 350 for 3 sec.		

**Technical Data Sheet****Luminosity Full Color LED****61-136/REGHB7C-B07/ET****Electro-Optical Characteristics (Ta=25)**

Parameter	Symbol	Min.	Typ.	Max.	Unit	Condition	
Luminous Intensity	I _v	RE	500	-----	700	mcd	I _F =20mA
		GH	700	-----	1300		
		B7	160	-----	260		
Viewing Angle	2 1/2	-----	120	-----	deg	I _F =20mA	
Peak Wavelength	p	RE	-----	632	-----	nm	I _F =20mA
		GH	-----	518	-----		
		B7	-----	468	-----		
Dominant Wavelength	d	RE	619.5	-----	631.5	nm	I _F =20mA
		GH	519.5	-----	531.5		
		B7	450.0	-----	462.0		
Spectrum Radiation Bandwidth		RE	-----	20	-----	nm	I _F =20mA
		GH	-----	35	-----		
		B7	-----	35	-----		
Forward Voltage	V _F	RE	1.8	-----	2.4	V	I _F =20mA
		GH	3.0	-----	3.6		
		B7	3.0	-----	3.6		

Note:

- 1.Tolerance of Luminous Intensity:±11%
- 2.Tolerance of Dominant Wavelength:±1 nm
- 3.Tolerance of Forward Voltage:±0.1V

**Technical Data Sheet****Luminosity Full Color LED****61-136/REGHB7C-B07/ET****Bin Range of Luminous Intensity**

Symbol		Bin Code	Min.	Max.	Unit	Condition
I _v	RE	R1	500	600	mcd	I _F =20mA
		R2	600	700		
	GH	G1	700	1000		
		G2	1000	1300		
	B7	B1	160	210		
		B2	210	260		

Bin Range of Dominant Wavelength

Symbol		Bin Code	Min.	Max.	Unit	Condition
d	RE	WR1	619.5	625.5	nm	I _F =20mA
		WR2	625.5	631.5		
	GH	WG0	519.5	525.5		
		WG1	525.5	531.5		
	B7	WB0	450.0	456.0		
		WB1	456.0	462.0		

Note:

- 1.Tolerance of Luminous Intensity:±11%
- 2.Tolerance of Dominant Wavelength:±1 nm

**Technical Data Sheet****Luminosity Full Color LED****61-136/REGHB7C-B07/ET****Bin Range of Forward Voltage**

Symbol		Bin Code	Min.	Max.	Unit	Condition
V_F	RE	VR0	1.80	2.00	V	$I_F = 20\text{mA}$
		VR1	2.00	2.20		
		VR1	2.20	2.40		
	GH	VG0	3.00	3.20		
		VG1	3.20	3.40		
		VG2	3.40	3.60		
	B7	VB0	3.00	3.20		
		VB1	3.20	3.40		
		VB2	3.40	3.60		

Note:1. Tolerance of Forward Voltage: $\pm 0.1\text{V}$

Technical Data Sheet

Luminosity Full Color LED

61-136/REGHB7C-B07/ET

Typical Electro-Optical Characteristics Curves (B7)

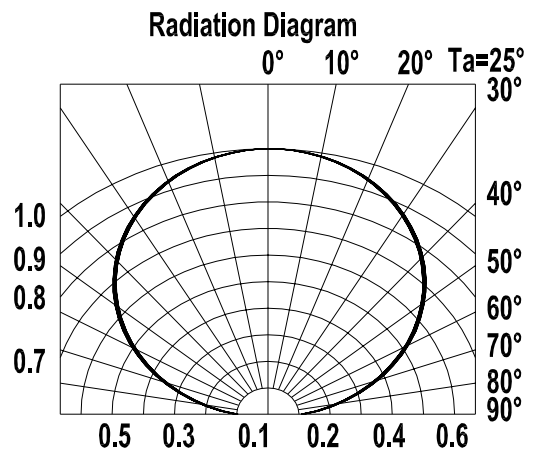
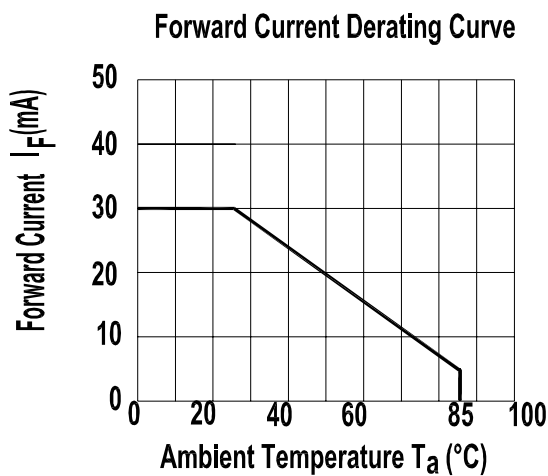
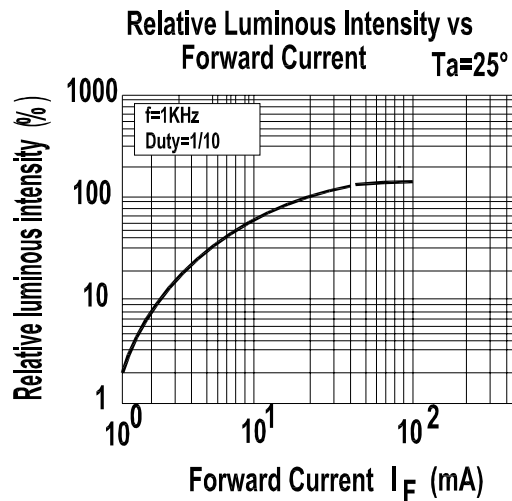
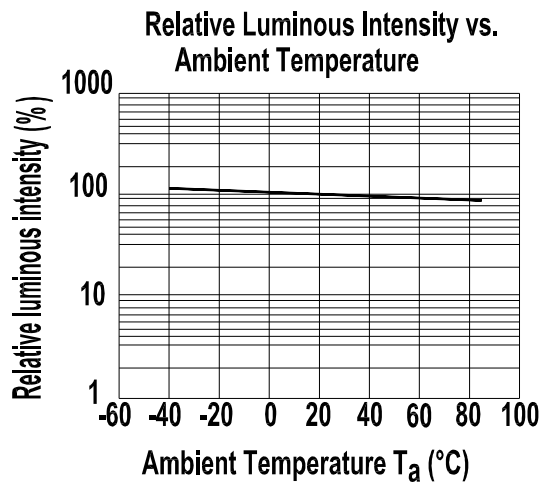
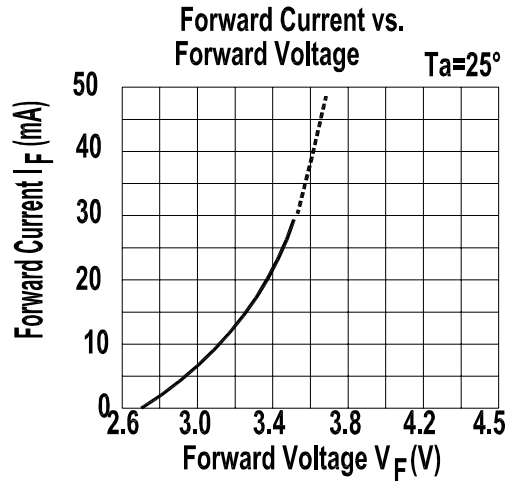
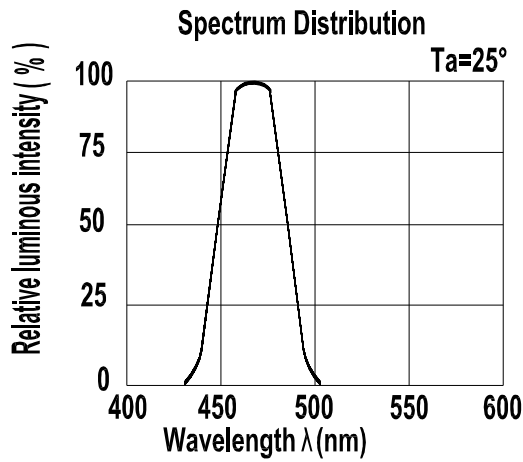

Technical Data Sheet

Luminosity Full Color LED

61-136/REGHB7C-B07/ET

Typical Electro-Optical Characteristics Curves (GH)

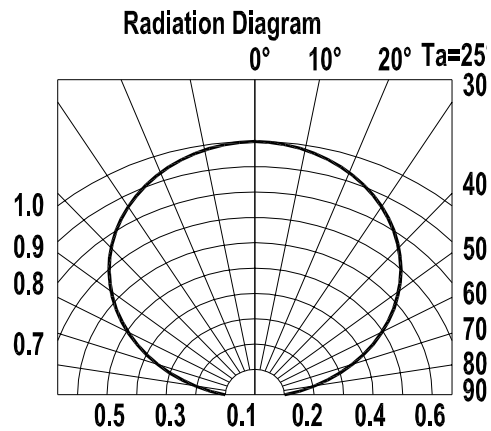
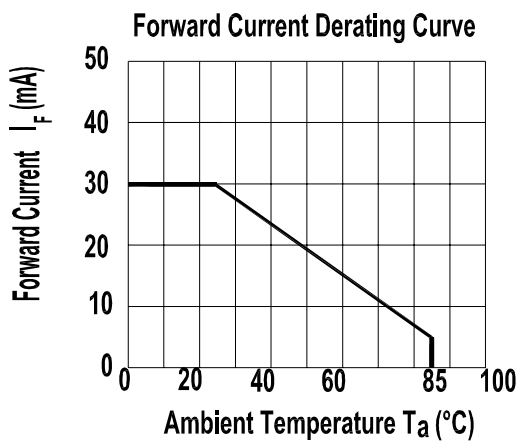
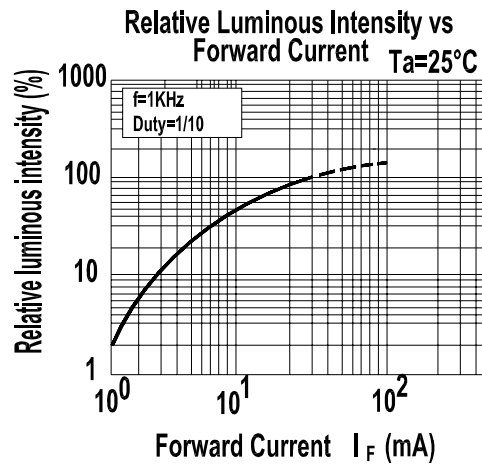
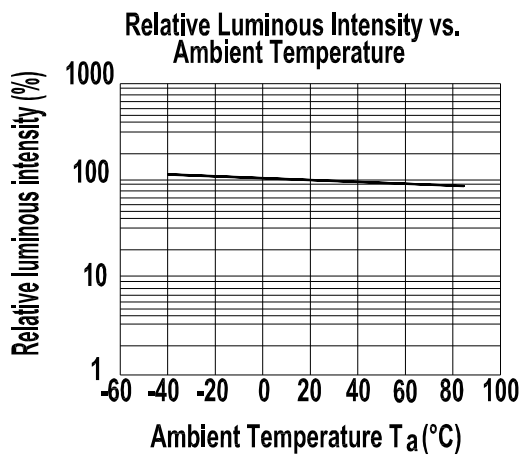
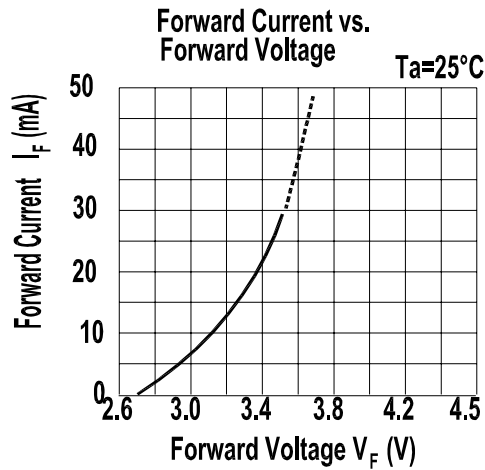
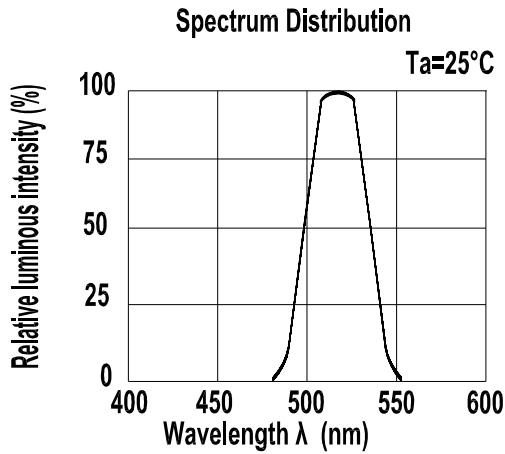

Technical Data Sheet

Luminosity Full Color LED

61-136/REGHB7C-B07/ET

Typical Electro-Optical Characteristics Curves (RE)

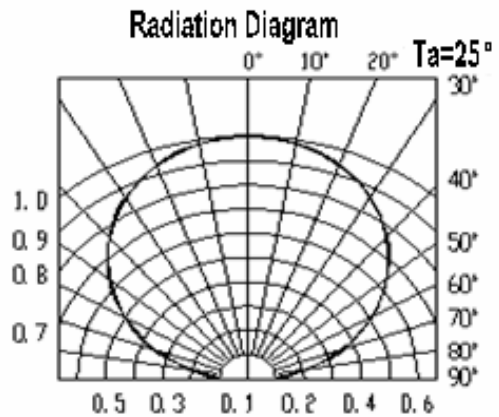
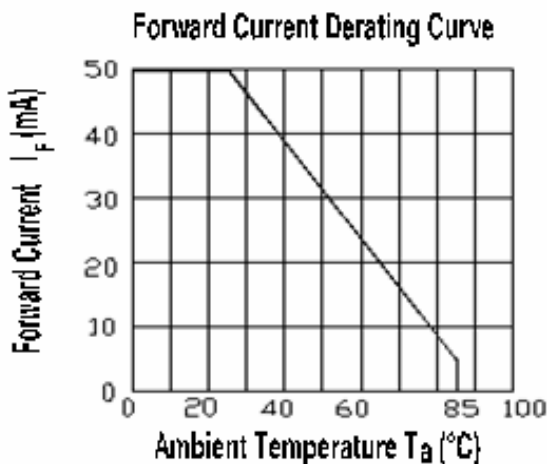
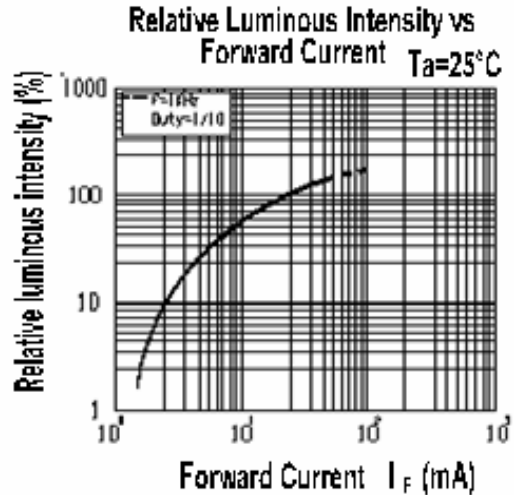
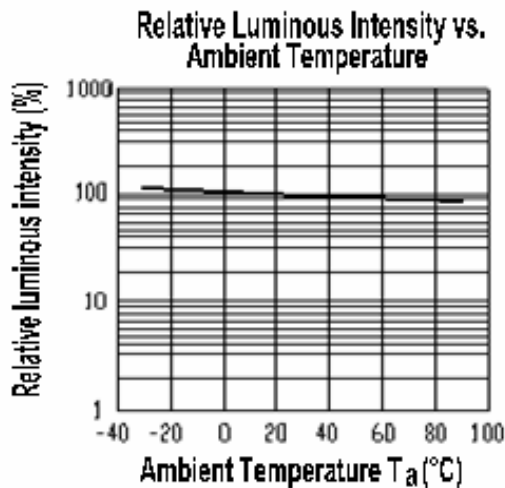
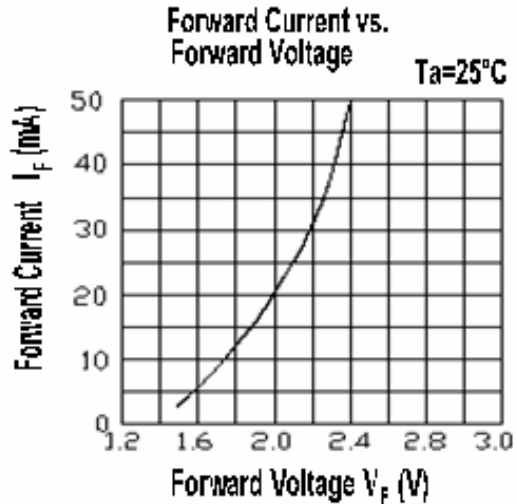
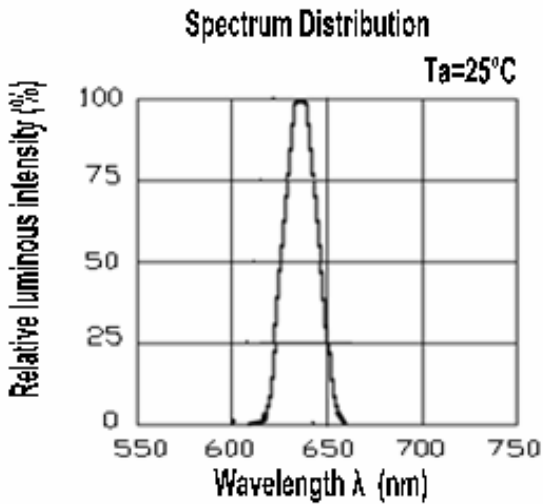



Technical Data Sheet

Luminosity Full Color LED

61-136/REGHB7C-B07/ET

Packing Specification

Label Explanation

- (1) CPN : Customer's Product Number
- (2) P/N : Product Number
- (3) QTY : Packing Quantity
- (4) CAT : Luminous Intensity Rank
- (5) HUE : Dom. Wavelength Rank
- (6) REF : Forward Voltage Rank
- (7) LOT No : Lot Number

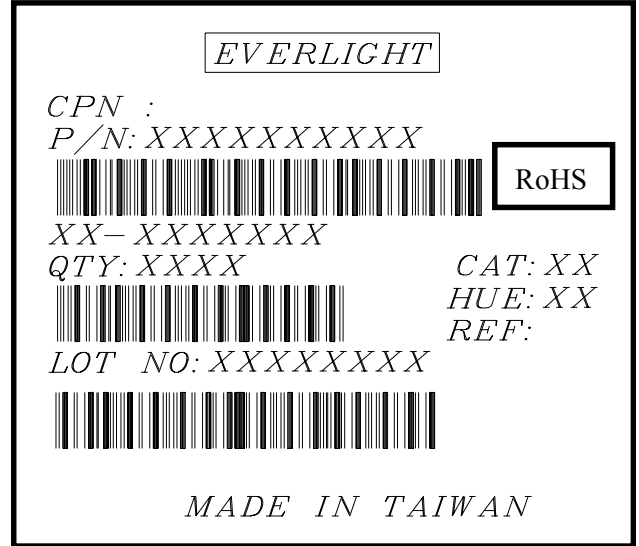

Reel Dimensions

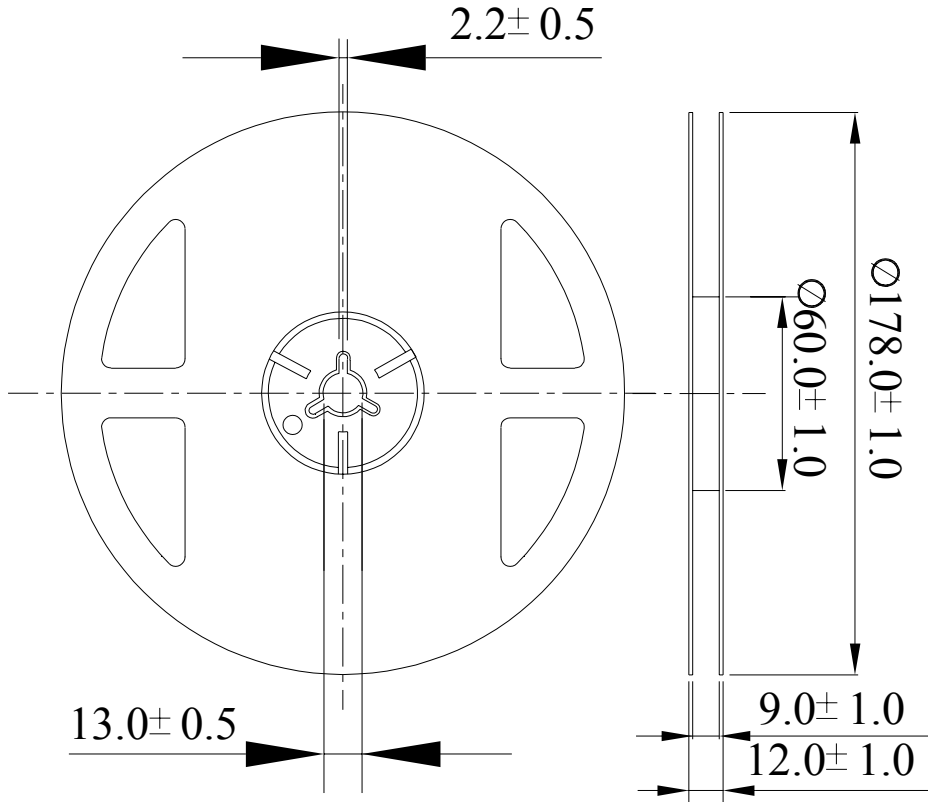

Note : Tolerances unless dimension:±0.1mm. Unit = mm

Technical Data Sheet

Luminosity Full Color LED

61-136/REGHB7C-B07/ET

Carrier Tape Dimensions: Loaded Quantity 800 pcs Per Reel

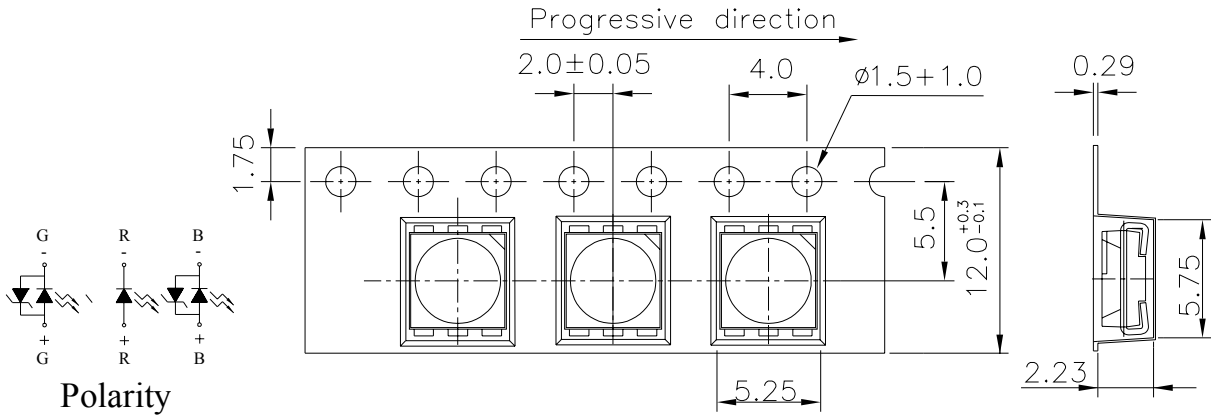

Note: The tolerances unless mentioned:±0.1mm ,Unit = mm

Moisture Resistant Packaging

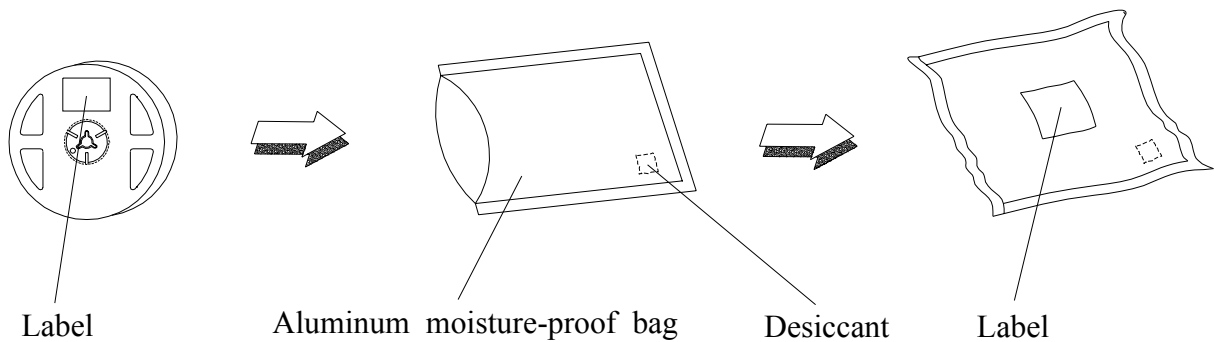

**Technical Data Sheet****Luminosity Full Color LED****61-136/REGHB7C-B07/ET****Reliability Test Items and Conditions**

The reliability of products shall be satisfied with items listed below.

Confidence level : 90%

LTPD : 10%

No.	Items	Test Condition	Test Hours/Cycles	Sample Size	Ac/Re
1	Reflow Soldering	Temp. : 260 ±5 Min. 5sec.	6 min	22 PCS.	0/1
2	Temperature Cycle	H : +100 15min ┆ 5 min L : -40 15min	300 Cycles	22 PCS.	0/1
3	Thermal Shock	H : +100 5min ┆ 10 sec L : -10 5min	300 Cycles	22 PCS.	0/1
4	High Temperature Storage	Temp. : 100	1000 Hrs.	22 PCS.	0/1
5	Low Temperature Storage	Temp. : -40	1000 Hrs.	22 PCS.	0/1
6	DC Operating Life	I _F = 20 mA	1000 Hrs.	22 PCS.	0/1
7	High Temperature / High Humidity	85 / 85%RH	1000 Hrs.	22 PCS.	0/1

Technical Data Sheet

Luminosity Full Color LED

61-136/REGHB7C-B07/ET

Precautions for Use

1. Over-current-proof

Customer must apply resistors for protection, otherwise slight voltage shift will cause big current change (Burn out will happen).

2. Storage

2.1 Do not open moisture proof bag before the products are ready to use.

2.2 Before opening the package: The LEDs should be kept at 30 °C or less and 90%RH or less.

2.3 After opening the package: The LED's floor life is 1 year under 30 °C or less and 60% RH or less. If unused LEDs remain, it should be stored in moisture proof packages.

2.4 If the moisture absorbent material (silica gel) has faded away or the LEDs have exceeded the storage time, baking treatment should be performed using the following conditions.

Baking treatment: 60±5 °C for 24 hours.

3. Soldering Condition

3.1 Pb-free solder temperature profile

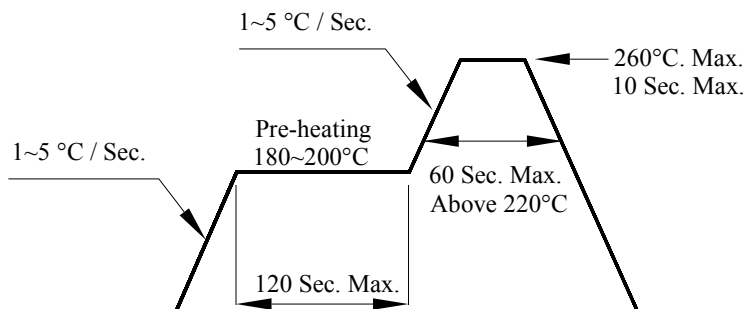

3.2 Reflow soldering should not be done more than two times.

3.3 When soldering, do not put stress on the LEDs during heating.

3.4 After soldering, do not warp the circuit board.

Technical Data Sheet

Luminosity Full Color LED

61-136/REGHB7C-B07/ET

4. Soldering Iron

Each terminal is to go to the tip of soldering iron temperature less than 350 for 3 seconds within once in less than the soldering iron capacity 25W. Leave two seconds and more intervals, and do soldering of each terminal. Be careful because the damage of the product is often started at the time of the hand solder.

5. Repairing

Repair should not be done after the LEDs have been soldered. When repairing is unavoidable, a double-head soldering iron should be used (as below figure). It should be confirmed beforehand whether the characteristics of the LEDs will or will not be damaged by repairing.

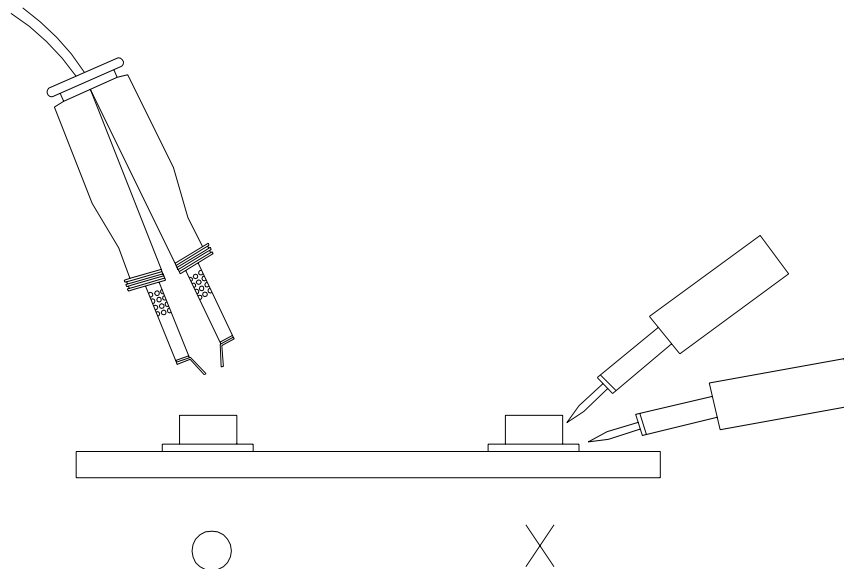

6. Handling Indications

During processing, mechanical stress on the surface should be minimized as much as possible. Sharp objects of all types should not be used to pierce the sealing compound

EVERLIGHT ELECTRONICS CO., LTD.

Office: No 25, Lane 76, Sec 3, Chung Yang Rd,
Tucheng, Taipei 236, Taiwan, R.O.C

Tel: 886-2-2267-2000, 2267-9936

Fax: 886-2267-6244, 2267-6189, 2267-6306

<http://www.everlight.com>